



**Pascal 2005, SD Version, 1-Phase
Motor, 180–254 V, 50/60 Hz,
CE/UL/CSA**



Similar Image

**Pascal 2005, SD Version, 1-Phase Motor, 180–254 V,
50/60 Hz, CE/UL/CSA**

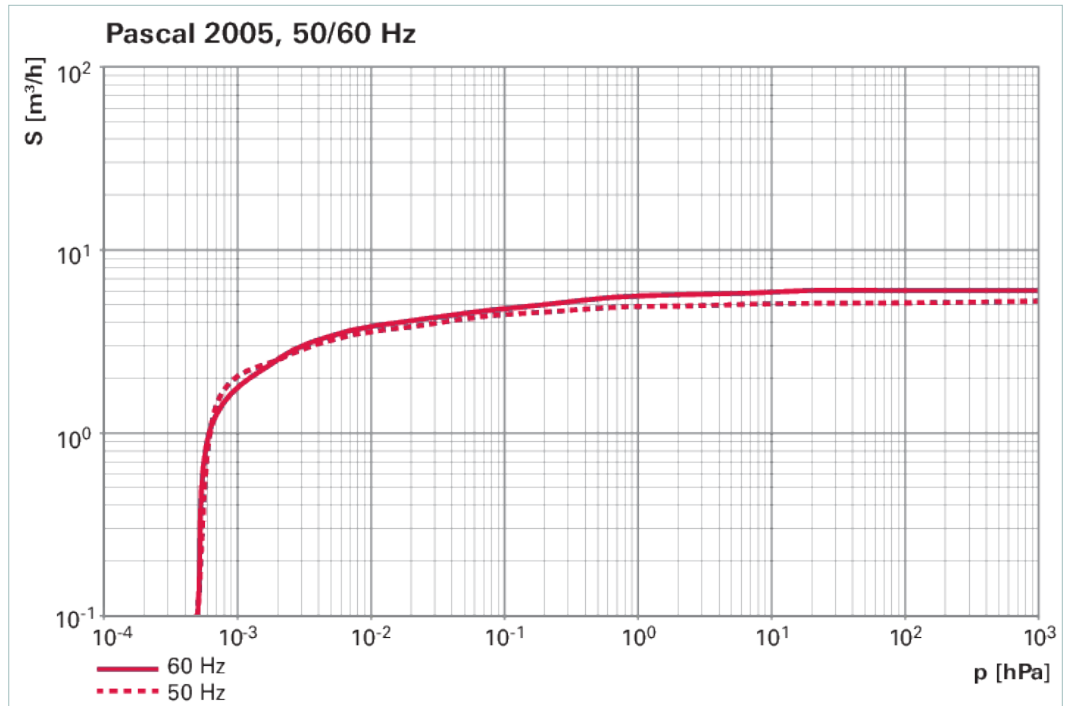
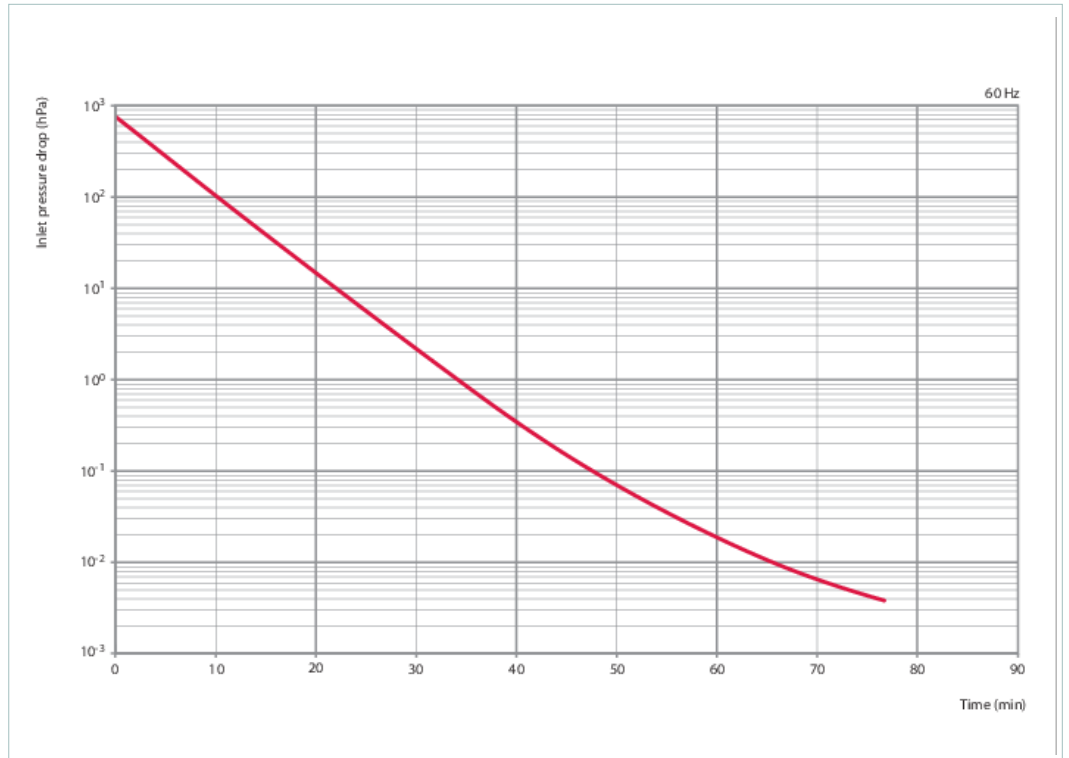

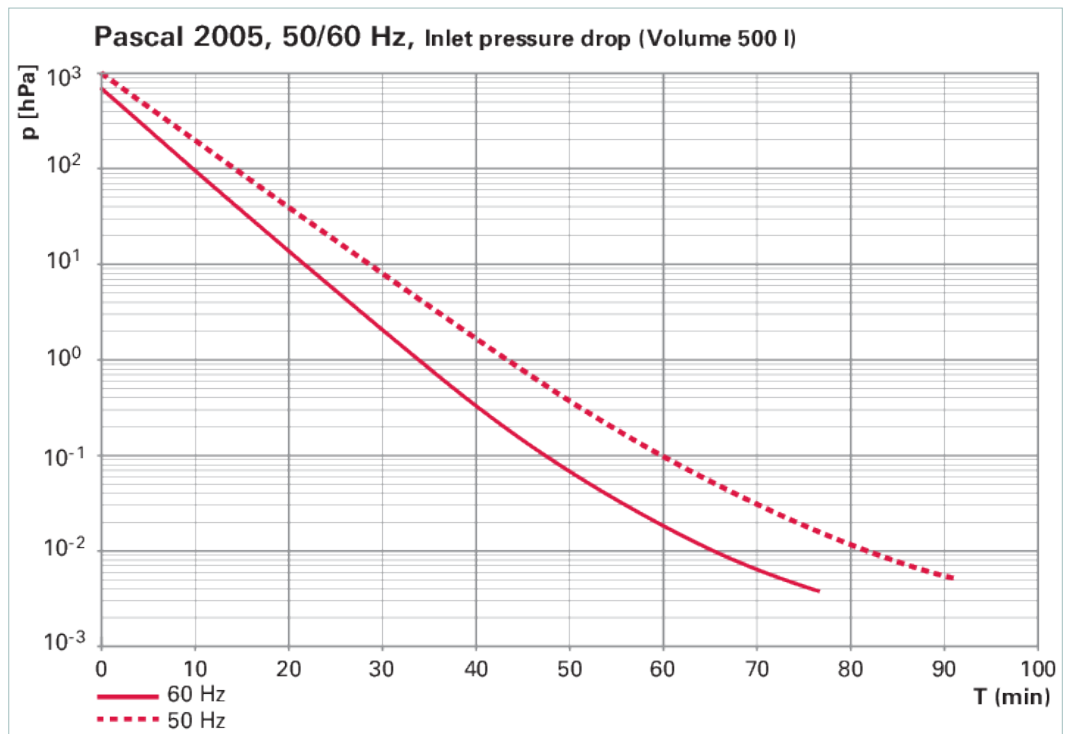

Dimensions

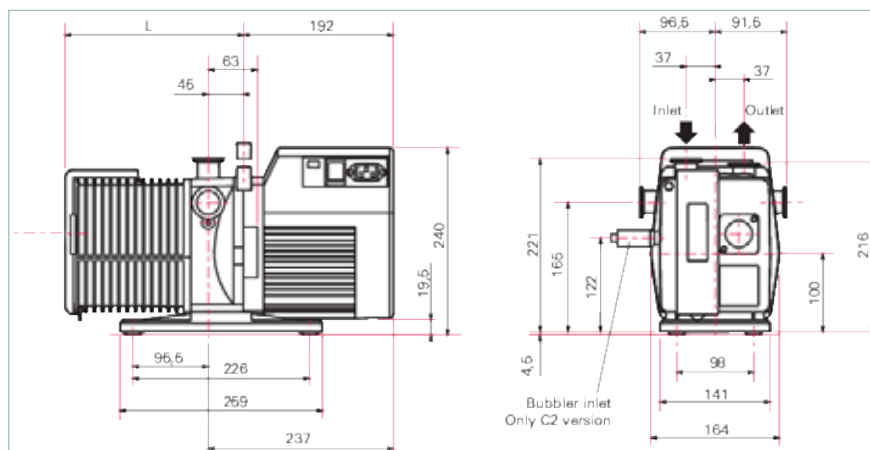

L 228 mm

Technical Data	Pascal 2005, SD Version, 1-Phase Motor, 180–254 V, 50/60 Hz, CE/UL/CSA
Connection flange (in)	DN 25 ISO-KF
Connection flange (out)	DN 25 ISO-KF
Pumping speed at 50 Hz	5 m ³ /h 2.94 cfm 83.33 l/min
Pumping speed at 60 Hz	6 m ³ /h 3.53 cfm 100 l/min
Final pressure	5 · 10 ⁻⁴ hPa 3.75 · 10 ⁻⁴ Torr 5 · 10 ⁻⁴ mbar
Final pressure with gas ballast	1 · 10 ⁻² hPa 7.5 · 10 ⁻³ Torr 1 · 10 ⁻² mbar
Final pressure without gas ballast	5 · 10 ⁻⁴ hPa 3.75 · 10 ⁻⁴ Torr 5 · 10 ⁻⁴ mbar
Motor type	1-ph motor
Mains connection: voltage 50 Hz	180 – 254 V
Mains connection: voltage 60 Hz	180 – 254 V
Mains cable	Yes, EU mains cable
Operating fluid	Mineral oil
Rated power 50 Hz	0.45 kW
Rated power 60 Hz	0.55 kW
Protection degree	IP43

Technical Data	Pascal 2005, SD Version, 1-Phase Motor, 180–254 V, 50/60 Hz, CE/UL/CSA
Weight	25 kg 55.12 lb

Order number	
Pascal 2005, SD Version	205SDMHEM

Accessories	
Monitoring	
Oil/Operating fluid level monitoring	
Oil level switch OLS 4	104376
Other	
Cold Trap, LN2, angled, DN 25 ISO-KF, 4" body, stainless steel / FPM	FTNA-4-1002-NWB
Protection	
Catalyzer traps	
URB 025, catalytic trap, 115 V	PT U10 761
URB 025, catalytic trap, 230 V	PT U10 760
Condensate separators	
KAS 25 L, condensate separator for pumping speeds up to 35 m ³ /h	PK Z10 033
Dust separators/Inlet particle filters	
SAS 25, Dust Separator, DN 25 ISO-KF	PK Z60 508
Oil mist eliminators	
Oil mist separator OME 25 S	104200
OME 25 M, oil mist separator for pumping speeds up to 12 m ³ /h	PK Z40 157
Oil return units from oil mist eliminators	
Oil Return Unit ODK1 from Oil Mist Separator	104360
Oil Return Unit ODK 2 from OME 25, Solenoid Valve 230 V 50/60 Hz, Pascal 2005–2021	104361
Oil Return Unit ODK 2 from OME 25, Pascal 2005–2021, Solenoid Valve 115 V, 60 Hz	104362
Oil Return Unit ODK 2 from OME 25, Pascal 2002–2021	104364
Oil return unit ODK 2 from OME 25, Pascal 2005–2021, solenoid valve 24 V DC	104365
Sorption traps	
Sorption trap ST 25 S	104107
Gas ballast valves, magnetic	
Automatic Gas Ballast AGB 4, 230 V, 50/60 Hz	104086
Automatic gas ballast AGB 4, 115 V	104087
Automatic Gas Ballast AGB 4, 24 VDC	104089
Automatic Gas Ballast AGB 4, 200 V, 50/60 Hz	104366
Consumables	
A120, hydrocarbon oil, 2 L	068099
A111, mineral oil, 2 L	064655
A102, hydrocarbon oil, 2 L	010996
A119, hydrocarbon oil, 1 L	103855
A121, hydrocarbon oil, 1 L	102724
D1, synthetic diester based oil, 1 l	PK 005 875 -T